

EXOSKELETON
www.hyetone.com

EXO

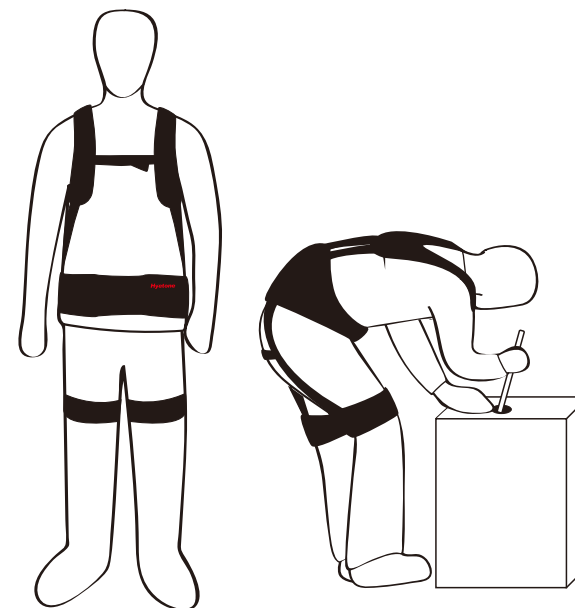

PHES | 弹性腰
PWIND0102

Quick Guide
产品使用说明



Hyetone 海同工业 www.hyetone.com

HOTLINE
400 018 2086

广州海同工业技术有限公司

地址：广东省广州市白云区西槎路聚龙工业区799号6栋一楼

电话：020-36464335

传真：020-36464300

武汉海同机器人控制系统有限公司

地址：湖北省武汉市洪山区邮科院路88号武汉国际创客中心

一号楼5层2区

电话：027-85630916

Guangzhou Hyetone Industrial Technologies Co., Ltd.

Block 6, 799 Xicha Rd., Baiyun District, Guangzhou,

Guangdong Province, P.R.China. 510407

Tel: +86-20-36464335

Fax: +86-20-36464300

Wuhan Hyetone Robotics and Control Systems Co., Ltd.

Zone 2, 5th Floor, Block 1, Wuhan International Creator

Center, 88 Youkeyuan Rd., Hongshan District, Wuhan,

Hubei Province, P.R.China. 430074

Tel: +86-27-85630916

Contents

目录

清单及参数	-----	P01
结构示意图	-----	P02
穿戴设置	-----	P04
使用建议	-----	P06
危险警示	-----	P07
联系我们	-----	P08
保修售后	-----	P09
Packing List&Specification	-----	P11
Vest Hardware	-----	P12
Setup	-----	P14
Use Tips	-----	P16
Warnings	-----	P17
Contact us	-----	P18
Warranty&After-sales service	-----	P19

清单及参数

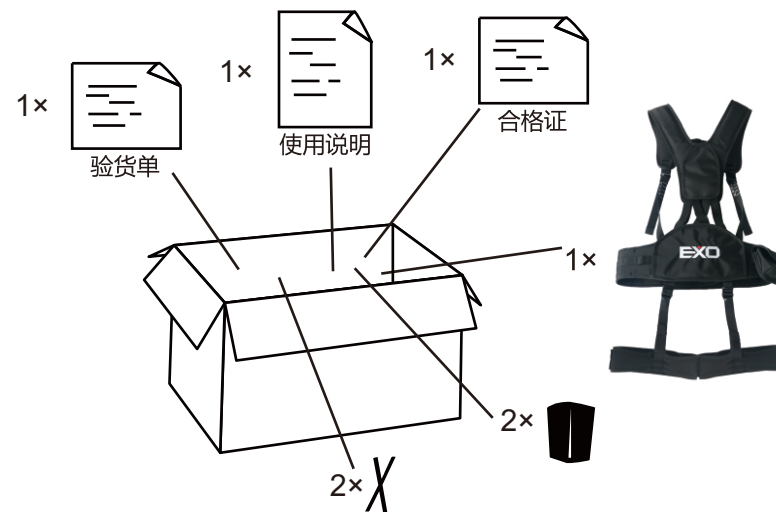

规格型号	PWIND0102
自重	≤1.2kg
适用身高	1.6~1.85m
适用体重	40~85kg
助力效果	≥50%

PW-IND-01-02-M-BK

产品 种类 规格 版本号 尺寸 颜色

注意

- 1.表中参数仅供参考，具体以实物铭牌为准
- 2.保留更改产品设计与规格的权利

结构示意图

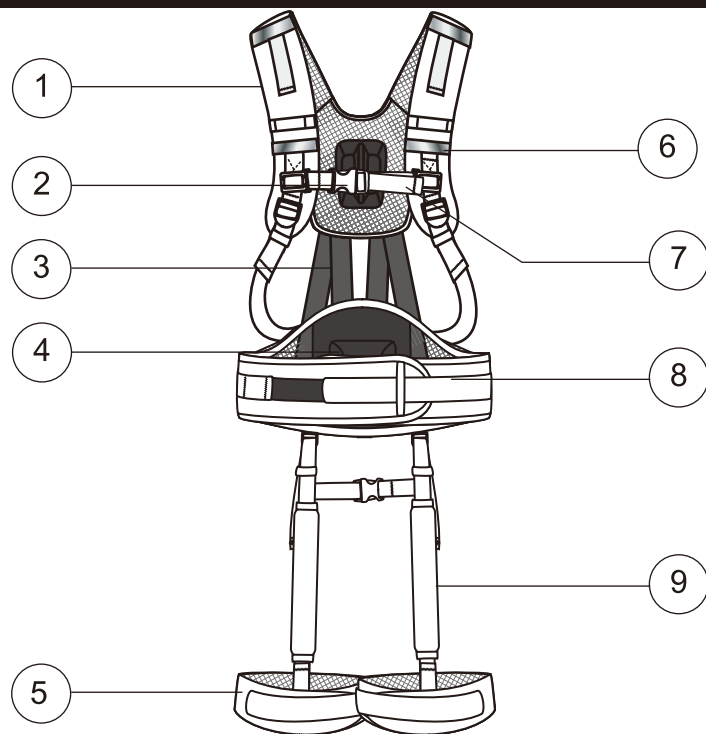

- | | |
|---------|--------|
| 1 背带 | 6 前反光带 |
| 2 上背垫 | 7 前调节扣 |
| 3 腰部助力带 | 8 腰带 |
| 4 下背垫 | 9 腿部拉簧 |
| 5 绑腿 | |

Maintenance/Repair

WARRANTY CARD

Name _____ Time _____

Model _____ Serial number _____

Date	Problem and Approach	Work done	Signature

One of the following conditions is not within the scope of the exemption

- Product failure caused by not complying with this quick guide
- Failure caused by self-disassembly and repair
- Failure caused by accident, misuse, misuse, intentional damage

Within one year from the purchase, under normal use, the purchaser can contact the manufacturer to provide free service with the sales invoice, "warranty card" and other purchase vouchers. For products that are out of warranty or are not subject to free repair, the company's technical service department will also provide paid services.

The manufacturing unit has the right to modify, and all contents in this manual have been carefully checked. If there are any printing errors or misunderstandings, the company reserves the right of final interpretation.



Contact

Thank you for choosing our products. Please fill up the "Warranty Card" and send it to us. Contact us on **400-018-2086** if you have any questions. We are happy to process your request.

Note

The information in this document is subject to change without notice. Please contact Customer Service for more information.

6th Building, 799 Xicha Rd., Baiyun District, Guangzhou, Guangdong Province, P.R.China. 510407
www.hyetone.com

结构示意图

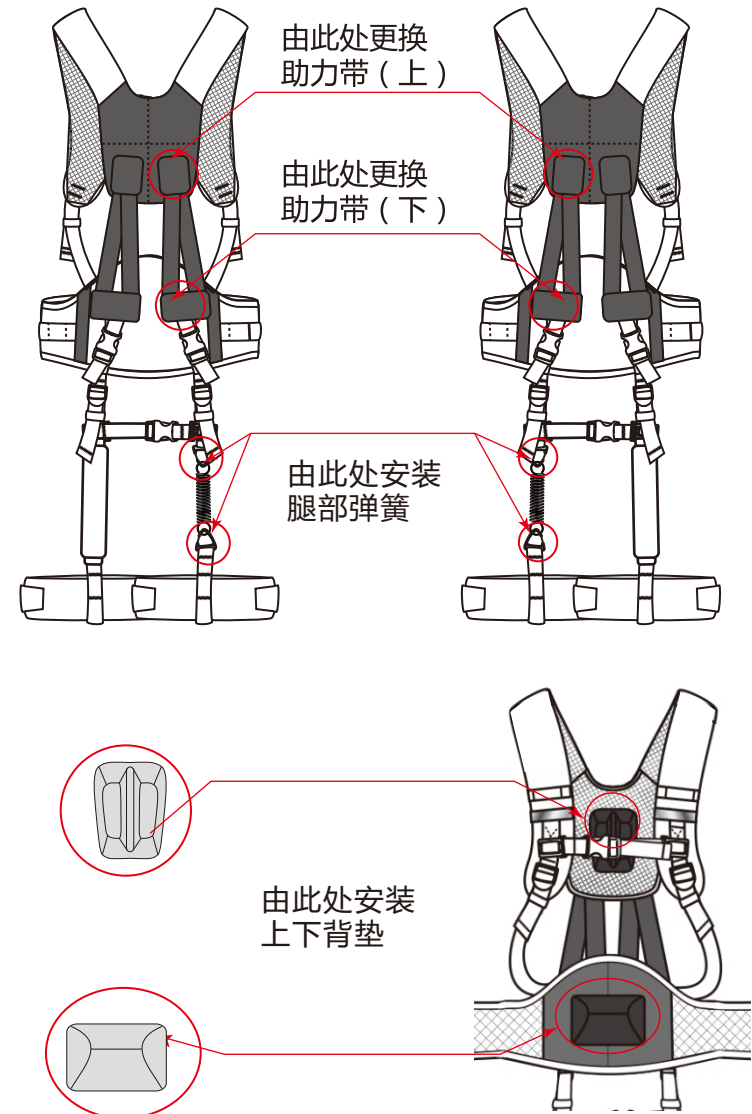

穿戴设置

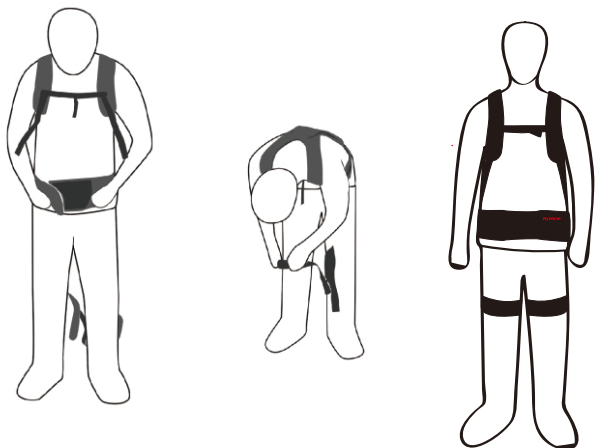
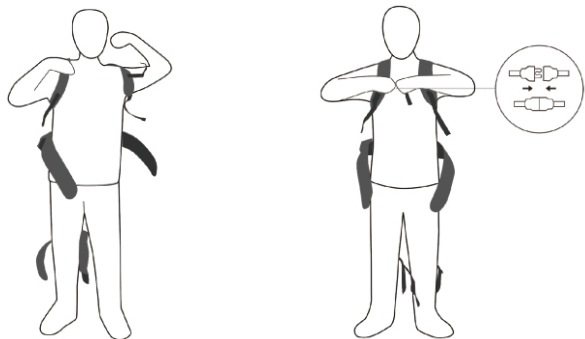
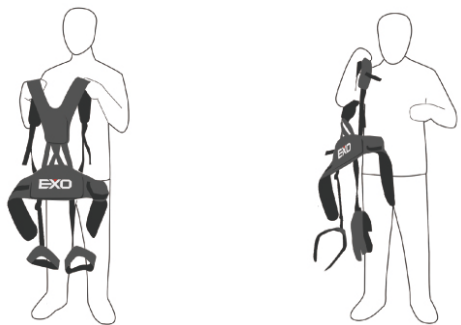

04

Warnings

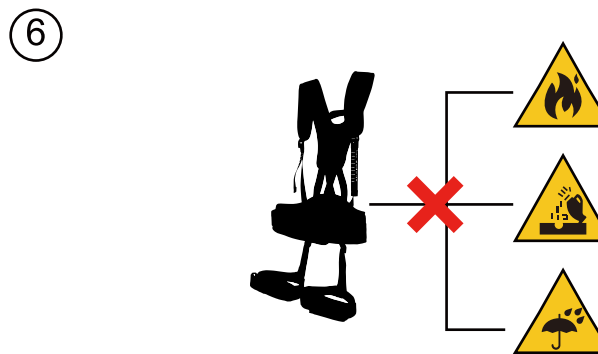
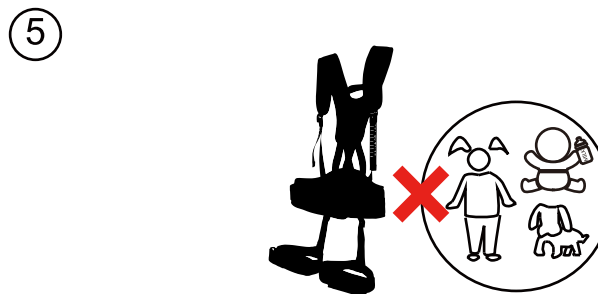
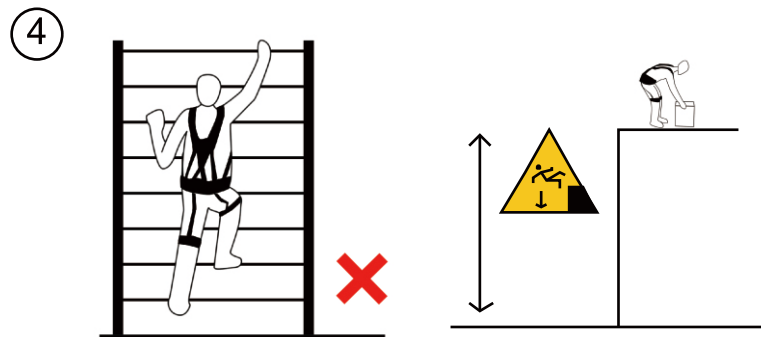

17

Use Tips

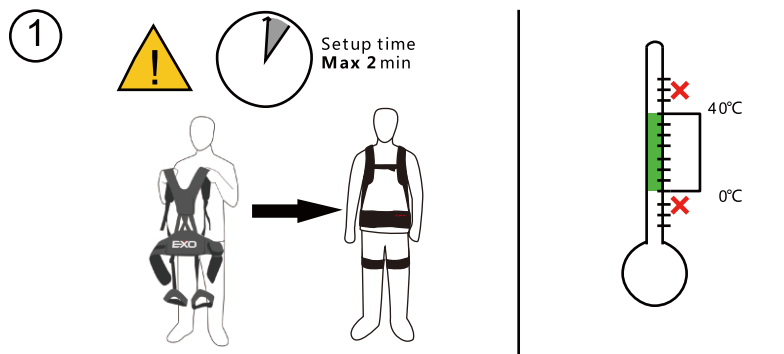

② First use

Day 1
max 1 hr

Day 2
max 2 hrs

Day 3
max 4 hrs

Day 4
max 8 hrs



③

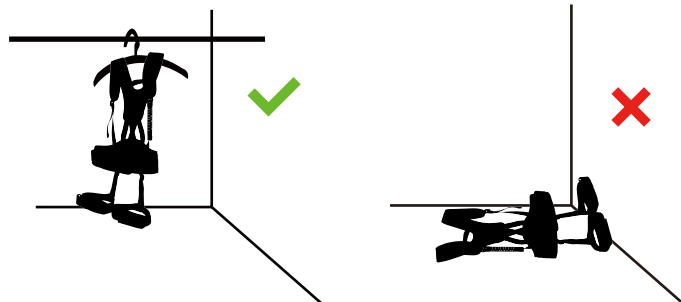

穿戴设置

- 1、使用前，注意检查产品是否有破损
- 2、魔术贴勾面，反光条，logo部位等部位处均都贴上一层保护膜,使用前,需撕掉保护膜方可使用.
- 3、上背垫贴至指定位置，下背垫贴至脊柱L3位置处
- 4、打开背部助力背盖，将两条助力带贴至同一水平线上，调整至适合自己的腰长，（如须调助力力度的大小，按压助力带尾端卡扣两侧，即可打开扣子）
- 5、绑腿连接扣尾端弧形处轻勾起，织带放松至初始状态
- 6、双肩穿入背带，扣紧胸前卡扣
- 7、腰带对齐髌关节处，贴紧腰带
- 8、绑腿带包裹住大腿（膝上10cm左右处）位置/包裹住小腿（膝盖髌骨位置处）（更换绑腿，绑腿连接扣尾端弧形处轻勾起，织带放松至初始状态，抽出织带进行更换）
- 9、拉住背带织带尾端向下拉，调至舒适位置
- 10、拉住绑腿连接带尾端向下拉，调至舒适状态（太紧，弯不下腰，轻勾起调节扣弧形处，放松织带；太松，弯腰无助力效果，拉住绑腿连接带尾端向下拉紧即可）

外骨骼视频讲解
请扫描右方二维码查看



使用建议

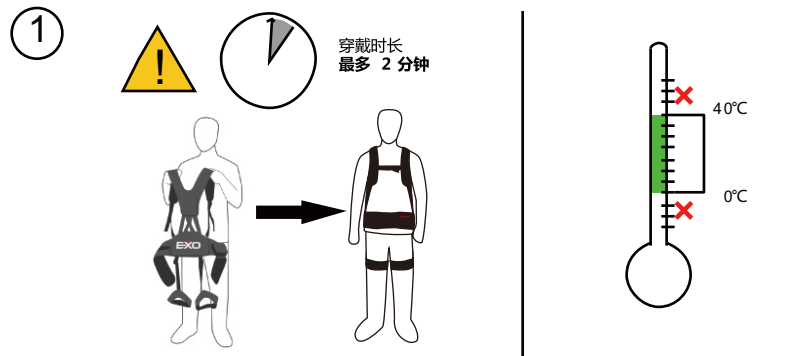

② 初次使用适应时长

第一天
最多 1小时

第二天
最多 2小时

第三天
最多 4小时

第四天
最多 8小时



③

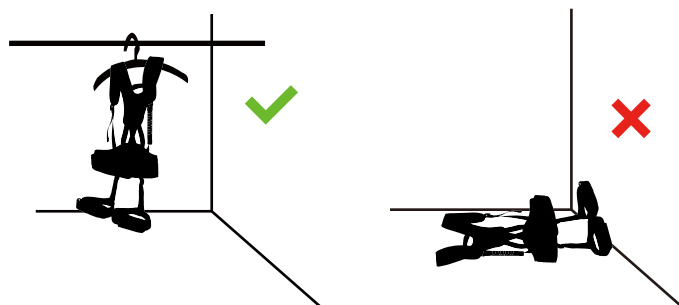

Setup/Preparations

1. Check the product for damage before donning it.
2. Velcro hook, reflective strip, LOGO and other parts are affixed with a layer of protective film, before use, need to tear off the protective film before use.
3. Attach upper torso pad on your T3, and attach lower torso pad on your L3.
4. Open the back cover and attach the two sets of elastic belts horizontally fit your waist. (pressing the sides of the buckle to adjust the proper elastic force)
5. Lift up the curved end of a strap to release the belt.
6. Put one strap over each shoulder and fasten the buckle on your chest.
7. Align the waist belt with the hip joint and tighten it.
8. Wrap around your thigh about 10cm above your knee and also wrap your knee. The belts are replaceable after being peeled off and taken off.
9. Keep your shoulder straps pulled forward and firm to make it comfortable.
10. Adjust to tighten leg belt and make things comfortable. (Not too loose, and not too tight)

Tutorial Video



Setup/Preparations

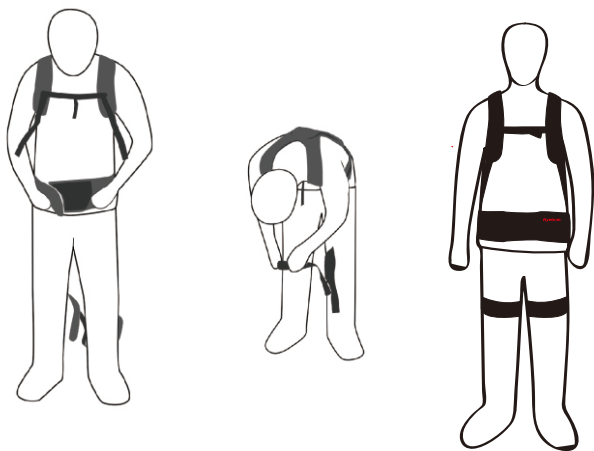
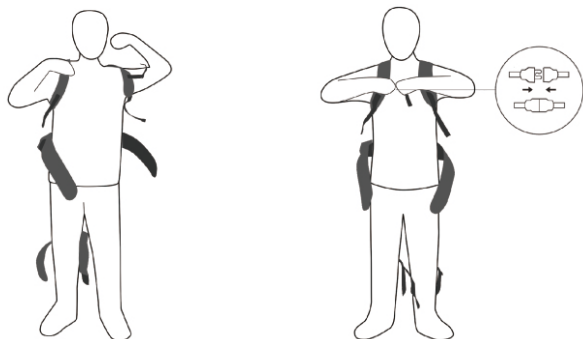
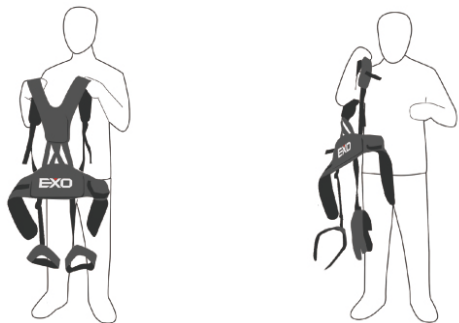

危險警示

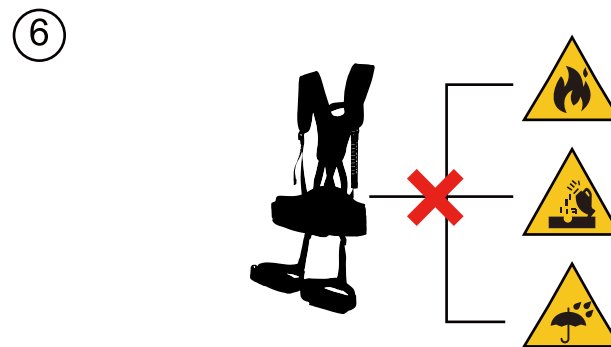
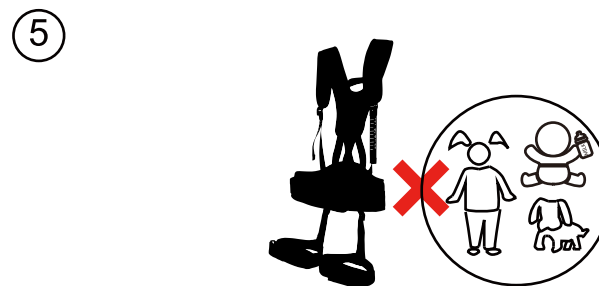
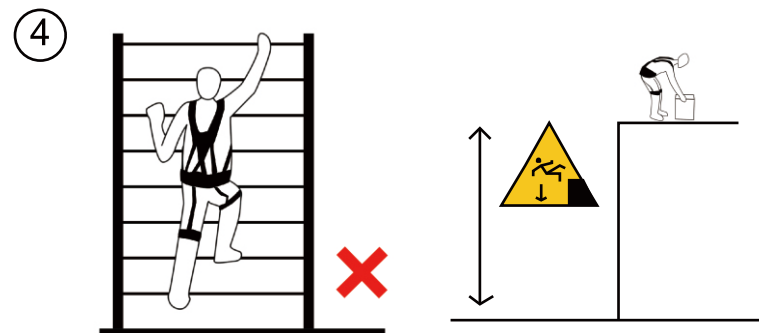

联系我们

感谢您对海同工业产品的信任与支持！为更及时的为您提供维修、咨询等服务，请认真填写《海同工业产品保修卡》，并妥善保管。您在使用过程中如有疑问，欢迎拨打全国服务热线400-018-2086与我们联系，我们将尽快给予您满意的答复。

地址：广州市白云区西槎路聚龙工业区799号6栋一楼

邮编：510407

公司网站：www.hyetone.com

注：此说明书内容会不定期进行修订，可能会与实际产品有出入，请电话咨询海同工业客服。

Spare Parts Replacement

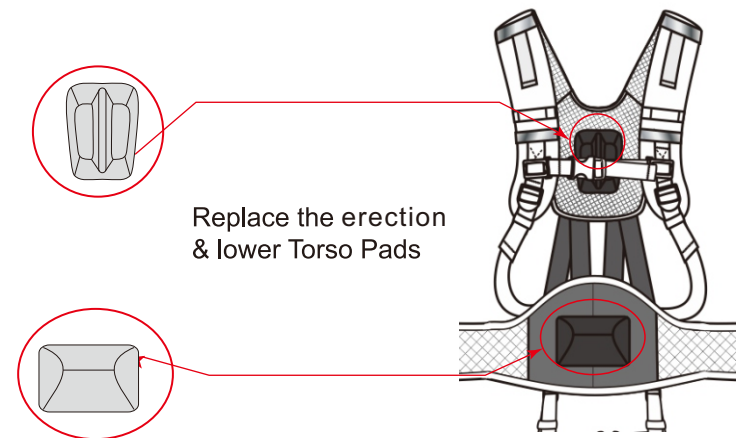
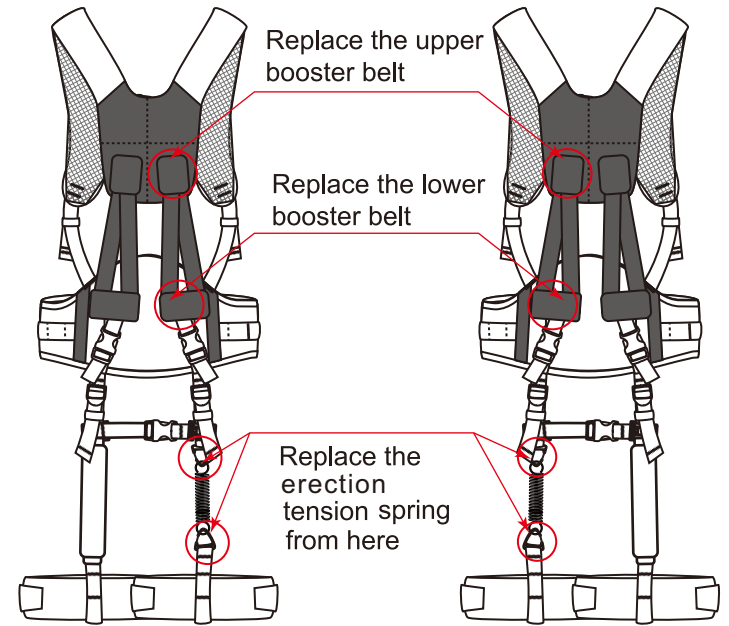

Spare Parts Replacement

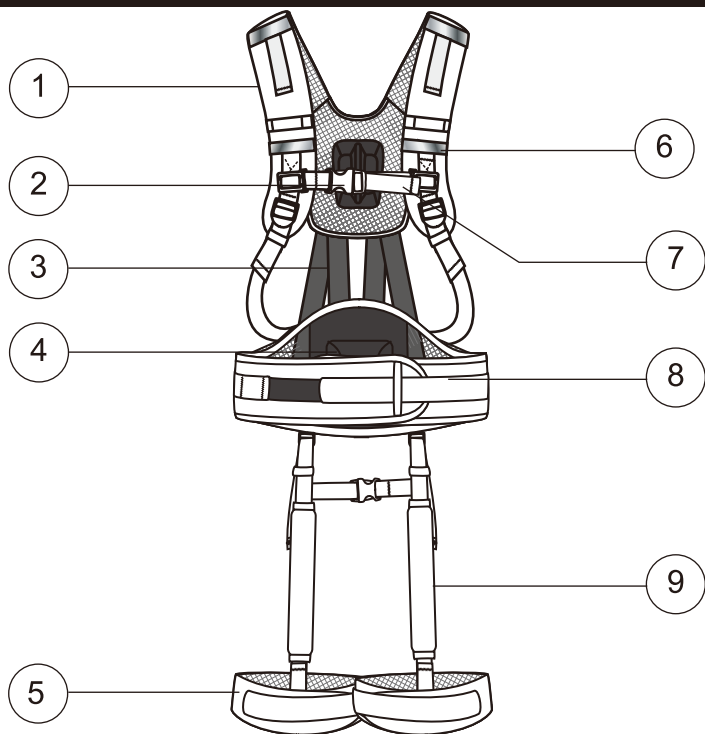

- | | | | |
|---|-----------------|---|-------------------------|
| 1 | Suspenders | 6 | Front Reflective Belt |
| 2 | Upper Torso Pad | 7 | Front Adjustment Buckle |
| 3 | Elastic Belts | 8 | Waist Belt |
| 4 | Lower Torso Pad | 9 | Leg tension spring |
| 5 | Legging | | |

保修售后

WARRANTY CARD

保 修 卡

顾客姓名 _____ 购买日期 _____
 产品型号 _____ 产品编号 _____

保修日期	故障及处理方法	完成日期	顾客签字

下列情况之一不在免修范围内

- 没有按说明书上的要求而造成的操作故障
- 由于自行拆卸、修理而造成的故障
- 由于意外、误用、乱用、故意损坏而造成的故障

售后服务

自购买起一年内，在正常使用情况下，购买者可凭销售发票、《保修卡》等购买凭证联系厂家提供免费服务。对于超过保修期或者不属于免费维修的产品，本公司技术服务部也会热情提供有偿服务。

注意

制造单位有改型的权利，恕不另行通知。本说明书上所有内容均经过认真核对，如有任何印刷错漏或内容上的误解，本公司保留最终解释权。



Packing List&Specification

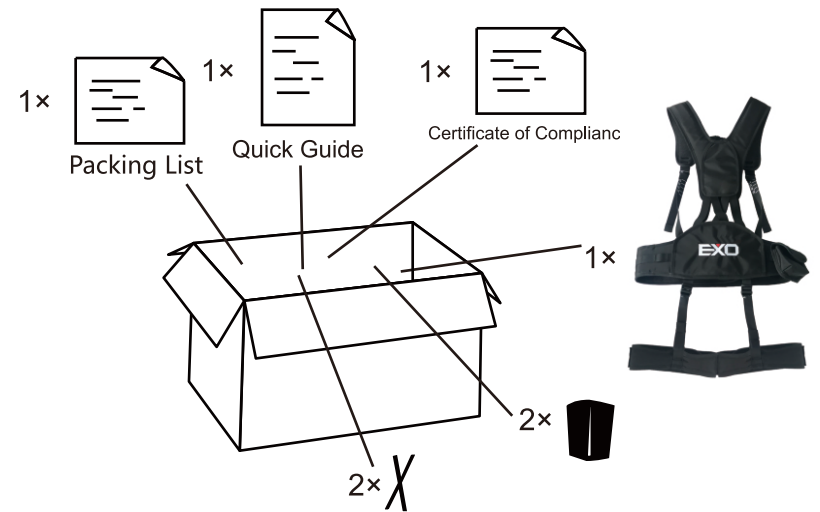

Model	PWIND0102
Weight	≤1.2kg
Worker Height Range	1.6~1.85m
Worker Weight Range	40~85kg
Adjustable Lift Assistance	≥50%

PW-IND-01-02-M-BK

Product Series Norm Code Size Color

Note

The information in this document is subject to change without notice. Please contact Customer Service for more information.

